

NOR-LAKE[®] SCIENTIFIC LARGE CAPACITY INCUBATORS

Designed to meet the demanding requirements for scientific and laboratory research. Advanced engineered design incorporates the latest in cabinet, refrigeration, temperature control and monitoring features. Provides energy efficient, convenient, safe and reliable performance for optimal storage temperature environments necessary for a wide range of life science, pharmacy, biological, medical, clinical, and industrial applications.

Standard Features:

- Digital 4x20 character LCD display microprocessor temperature controller
- Audible and visual Hi/Lo temperature alarm
- Adjustable control range from 5°C above ambient to 70°C on solid door models and 5°C above ambient to 60°C on glass door models
- Programmable ramp and soak
- Remote alarm contacts
- Continuous product temperature display
- 3 sensor system, 1 product, 2 air
- Power supply switch
- Door ajar alarm, audible and visual
- 2 to 10 volt DC output for product temperature (selectable to air temperature)
- Password protection – set-points and factory settings
- 100 event alarm logging date/time display
- Integrated Hi/Lo product temperature alarm test
- Digital calibration air and product
- Real time clock with date and time display
- Door opening counter with 24 hour automatic reset
- Adjustable alarm beep or constant on (key pad selectable)
- Alarm volume adjustable manually
- Low battery test switch with buzzer
- Sensor failure alarm
- Power failure alarm
- Exterior cabinet front, sides and back are painted white
- Exterior cabinet top and bottom are galvanized steel
- Interior cabinet liner is stainless steel
- Cabinet is foamed-in-place with CFC Free high density polyurethane foam insulation
- Full size doors
- Heavy duty door pivot hinges
- Pull door handles
- Magnetic door gaskets
- Centered key door lock(s) (2 keys)
- Four casters (2 locking), 2 leveling legs
- 3 solid stainless shelves
- Top mounted forced air heating system
- Warranties: 18 month parts and labor, 18 months parts (International)
- UL/CUL listed

Optional Features:

- Extra shelf
- Reverse hinge door, solid door only
- Stainless steel exterior
- Temperature chart recorder with chart paper
- 4-20ma output for product temperature (selectable to air temperature)
- RS-485 communications port (MODBUS-RTU)
- Ethernet 10 baseT (HTTP) control monitoring web card
- Secure Guard II Lock ProxKey (Factory Installed)
- Secure Guard II MagKey (Factory Installed)
- Secure Guard II Lock Software
- Seismic mounting kit
- Electrical duplex outlet
- Access port 2" with sleeve and cover
- Sensor access port 1" diameter
- Export crating



NSHI331WSG/



NSHI331WSW/

NSHI331WSG/

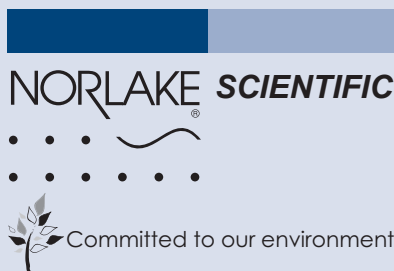

Nor-Lake, Inc.
Registered to ISO 9001:2008
File No. 10001816

NOR-LAKE SCIENTIFIC
A Division of
NOR-LAKE, INCORPORATED
727 Second Street
Hudson, Wisconsin 54016

800-477-5253
715-386-2323
800-388-5253 PARTS
715-386-4290 FAX
www.norlakescientific.com

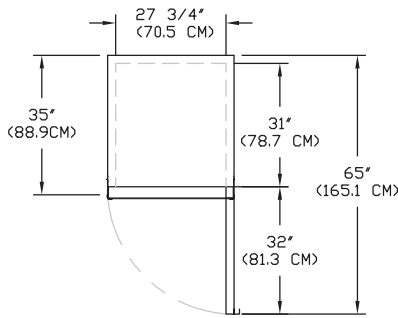

Top View - NSHI331WSW/0

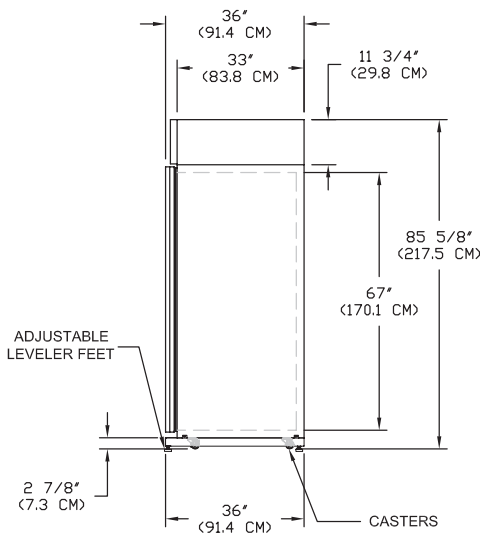

Side View - NSHI331WSW/0

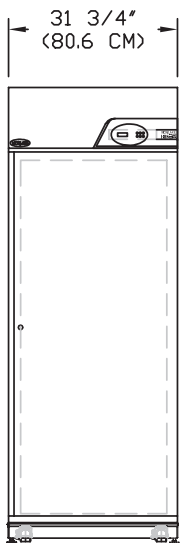

Front View - NSHI331WSW/0

SPECIFICATIONS

Glass Door Models	NSHI331WSG/0	NSHI331WSG/5
Solid Door Models	NSHI331WSW/0	NSHI331WSW/5
Crated Height (in) (cm)	89-3/4" (228)	89-3/4" (228)
Crated Width (in) (cm)	36-1/4" (92)	36-1/4" (92)
Crated Depth (in) (cm)	39-7/8" (101)	39-7/8" (101)
Crated Weight (lbs) (kg)	420 (190)	420 (190)
Interior Height (in) (cm)	67" (170)	67" (170)
Interior Width (in) (cm)	27-3/4" (70)	27-3/4" (70)
Interior Depth (in) (cm)	31" (78)	31" (78)
Overall Height (in) (cm)	85-5/8" (217)	85-5/8" (217)
Overall Width (in) (cm)	31-3/4" (80)	31-3/4" (80)
Overall Depth (in) (cm)	Solid Door: 36" (91) Glass Door: 36-1/2" (92)	Solid Door: 36" (91) Glass Door: 36-1/2" (92)
Gross Cubage (ft.3) (m3)	33.1 (.9)	33.1 (.9)
Shelf Area (sq. ft.) (m2)	14.1 (1.3)	14.1 (1.3)
Number of Shelves	3	3
Total Amp Draw	8.7	4.7
Maximum Fuse Size	15 AMPS	15 AMPS
Electrical Characteristics	115/60/1	230/50/1

Specifications subject to change without notice.

Voltage Model Suffix Code	Voltage Description	NEMA Plug	NEMA Receptacle
/0	115V, 1PH, 60HZ	5-15P	5-15R
/5	230V, 1PH, 50HZ	Power Inlet (IEC 60320) Module	Cord Supplied Locally

NORLAKE SCIENTIFIC

Revision Date: 11/10
 ©2010 NOR-LAKE, INC.
 Printed in the U.S.A.
 Part Number: 132585