

Miele

Top-class safety, cleanliness and material compatibility.
Laboratory Glassware Washers.

Miele Professional. Immer Besser.



PLW 6111
SlimLine lab washer

Contents

PLW 6111 SlimLine

Product benefits	4
Machine overview	6
Accessories	8

ProCare Lab

Process chemicals for the perfect reprocessing of laboratory glassware and utensils	21
Chemicals valid in USA 	24
Chemicals valid in Canada 	26

Service

Functional safety and preservation of values	32
--	----

LEGEND



Valid in USA



Valid in Canada



The new SlimLine lab washers – Compact dimensions, high capacity

With its new SlimLine lab washers, high-performance reprocessing methods, perfectly matching ProCare Lab process chemicals and practical accessories, Miele is offering a comprehensive and systematic solution to the reprocessing of laboratory glassware for analytical experiments. Going beyond standard approaches, Miele engineers, together with end users, have come up with individualized solutions to tackle everyday laboratory challenges.



Product benefit overview

PLW 6111



Efficient Chamber Space – flexible use of chamber space

The new SlimLine lab washers from Miele Professional excel in terms of high performance on a small footprint. And what's more, the innovative rack configuration enables chamber space to be used in an efficient manner.

Models from the PLW 6111 series are able to accommodate up to 3 baskets on telescopic racks. These baskets dock onto the water circulation system at 4 different heights. This allows a wide range of load height combinations, starting with using the lowest rack level only for a maximum vertical clearance of 25" (630 mm).



Compact machine dimensions combined with large chamber capacity

- Small footprint with width of only 650 mm
- 3 levels with injector nozzles
- Vertical clearance of up to 25" (630 mm) for large vessels
- 121 pipettes or 40 bottles (1 l) in a single cycle



Spotless results through combination of program cycle and process chemicals

- ProCare Lab process chemicals for optimum results
- Thorough cleaning combined with the gentlest treatment of materials
- Detergents and neutralizing agents in various canister sizes



Intelligent controls

- Controls with flush, uninterrupted touch glass screen
- All information visible at a glance thanks to 3.5" display
- Maximum of 40 program slots (standard program and vacant program slots)
- Simple and effective cleaning
- USB port connection (Canada version only)
- Printer connection (USA version only)



Simple and efficient cleaning processes

- Chamber, spray arms and tank filters are made from high-grade stainless steel (DIN 1.4404/AISI 316L)
- Conductivity monitoring for high-level process security (version dependent)
- HEPA H14 fine filter for germ-free drying air



Visual monitoring of chamber

- Process control thanks to full glass door
- Integrated chamber lighting
- Automatic door lock

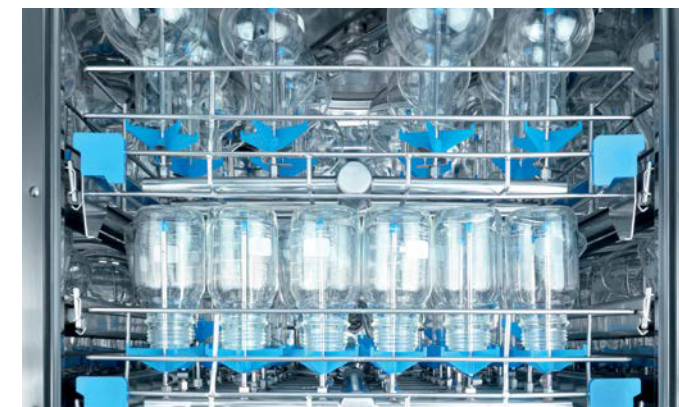

Wide range of load carriers

- Range specifically designed for laboratory use
- Maximum flexibility combined with intuitive use
- Wide range of standard and configurable loading options
- Possibility to reprocess even the smallest items of laboratory glassware through to very large containers (up to 50 l)

The new SlimLine lab washers

PLW 6111



Efficient Chamber Space
3 racks
4 levels

SlimLine lab washer	PLW 6111
External dimensions	73 5/8" (1870 mm) H x 25 9/16" (650 mm) W x 27 1/16" (687 mm) D
Overall chamber dimensions	33 7/8" (860 mm) H x 21 1/4" (540 mm) W x 23" (585 mm) D
Chamber opening dimensions	26 3/16" (665 mm) H x 21 1/4" (540 mm) W x 23" (585 mm) D
Usable volume [l]	210
Load concept	Rack system with max. 3 levels and 4 different positions
Program	40 program positions
Program selection	Touch on Glass
Features	
Single-door model	•
Glass door, bottom-hinged, chamber lighting	•
Electric heating	•
Hot-air drying, incl. HEPA H14 filter	•
Steam condenser	•
Printer connection (USA version only)	• USB port connection (Canada version only)
Boiler (USA version only)	•
Integrated dispenser pumps	2
Drain pump	•
Water connections	HW, CW, demineralized water
Electrical connection 3 AC 208V, 60 Hz	•
Total rated load [kW]	8.25
Conductivity meter & Sampling tap	version-dependent
Load capacity	
100 ml laboratory bottles	126
250 ml laboratory bottles	84
1000 ml laboratory bottles	40
Vials	468
Pipettes	121

Feature Summary

PLW 6111 Versions	Electric Heating	Drain Pump	Boiler	Steam Condenser	Chamber Lights	Hot-air HEPA 14	Printer	USB	Conductivity Sensor	Sampling Tap
USA Versions										
PLW6111 DP BO SC CL H14 PR	•	•	•	•	•	•	•			
PLW6111 DP BO SC CL H14 PR CS SV	•	•	•	•	•	•	•		•	•
Canada Versions										
PLW6111 DP SC CL H14 USB	•	•		•	•	•		•		
PLW6111 DP SC CL H14 USB CS SV	•	•		•	•	•		•	•	•

PLW 6111 Vertical level position clearances

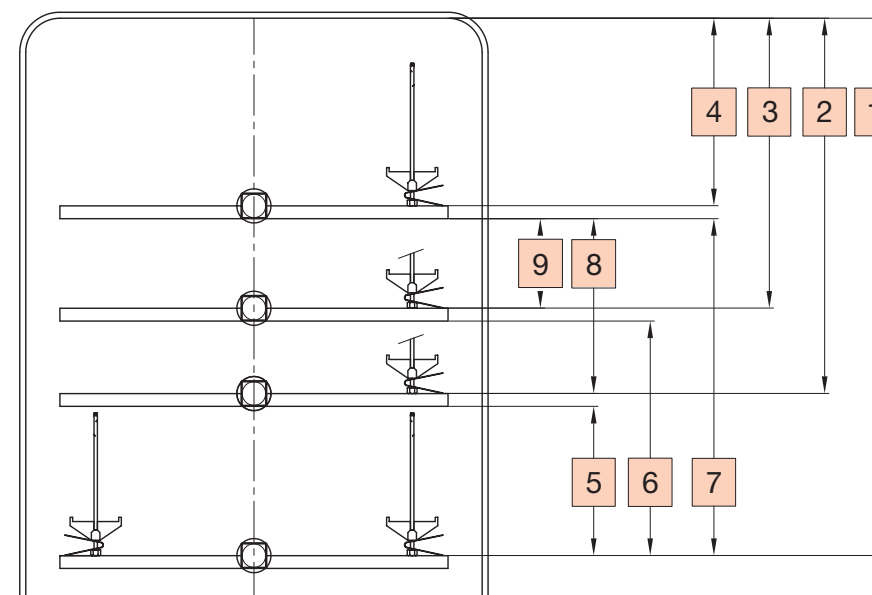

PLW 6111 Vertical level position clearances		
1	630 mm	24 13/16"
2	440 mm	17 5/16"
3	340 mm	13 3/8"
4	220 mm	8 11/16"
5	170 mm	6 11/16"
6	270 mm	10 5/8"
7	390 mm	15 3/8"
8	200 mm	7 7/8"
9	100 mm	3 15/16"

Standard baskets

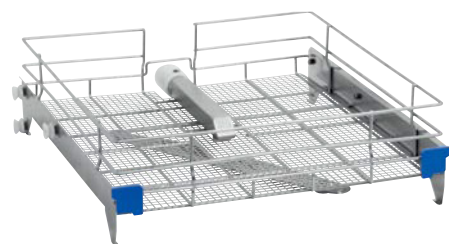

- APLW 000 upper basket**
- For laboratory glassware, e.g. beakers
 - Useable surface: 485 x 525 mm
 - H 165mm W 535mm D 565mm



- APLW 001 lower basket**
- For laboratory glassware, e.g. beakers
 - Useable surface: 490 x 540 mm
 - H 135mm W 535mm D 570mm

Inserts

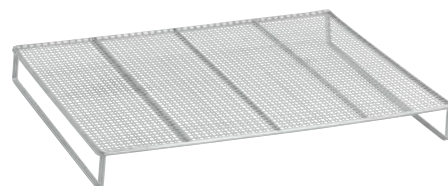

- APLW 033 mesh tray cover**
- Vertical clearance reduced by 50 mm
 - H 50mm W 485mm D 445mm

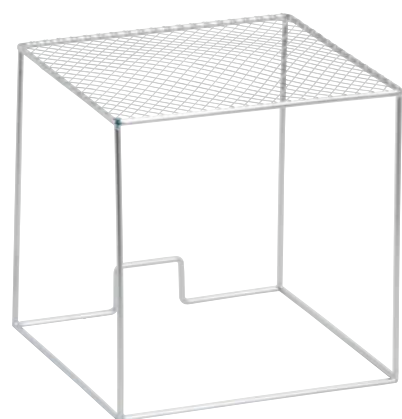

- APLW 034 cover**
- Cover for light-weight laboratory glassware, e.g. test tubes
 - For 121 position test tubes. H 250mm
 - H 250mm W 248mm D 248mm

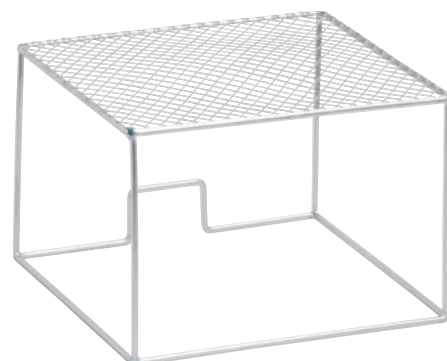

- APLW 035 cover**
- Cover for light-weight laboratory glassware, e.g. test tubes
 - For 121 position test tubes. H 175mm
 - H 175mm W 248mm D 248mm

Inserts



- APLW 036 cover**
- Cover for light-weight laboratory glasswares, e.g. test tubes
 - For 121 position test tubes. H 45mm
 - H 45mm W 248mm D 248mm



- APLW 037 protective grid**
- Adjustable protective cover for the safe reprocessing of test tubes
 - For 121 position test tubes
 - H 255mm W 365mm D 365mm



- APLW 038 insert**
- Insert with 28 spring hook for laboratory glassware
 - 14 spring hooks, 175 mm
 - 14 spring hooks, 105 mm
 - H 180mm W 400mm D 190mm



- APLW 039 insert**
- For Petri dishes
 - 26 placemats
 - H 83mm W 237mm D 430mm

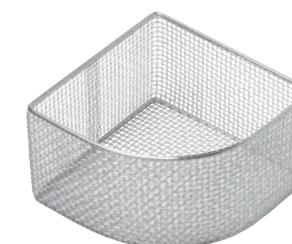

- APLW 040 1/4 mesh basket**
- For test tubes
 - Height 115 mm with accessory cover
 - H 100mm W 220mm D 220mm

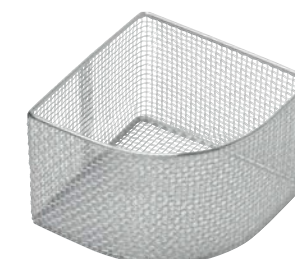

- APLW 041 1/4 mesh basket**
- For test tubes
 - Height 145 mm with accessory cover
 - H 130mm W 220mm D 220mm

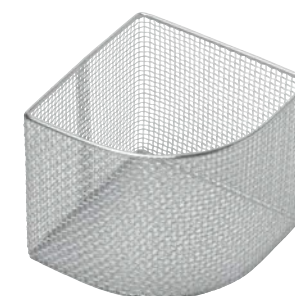

- APLW 042 1/4 mesh basket**
- For test tubes
 - Height 215 mm with accessory cover
 - H 200mm W 220mm D 220mm

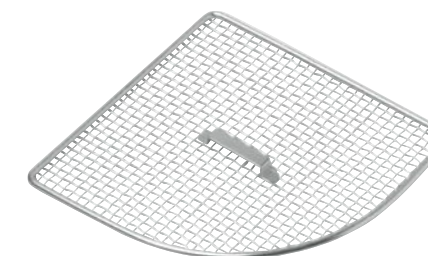

- APLW 043 1/4 mesh basket cover**
- Cover for APLW 040, APLW 041 and APLW 042
 - H 15mm W 220mm D 220mm

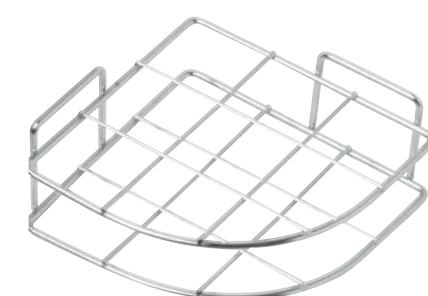

- APLW 044 1/4 mesh basket separator**
- For test tubes
 - Separator for APLW 040, APLW 041 and APLW 042

Pre-configured baskets

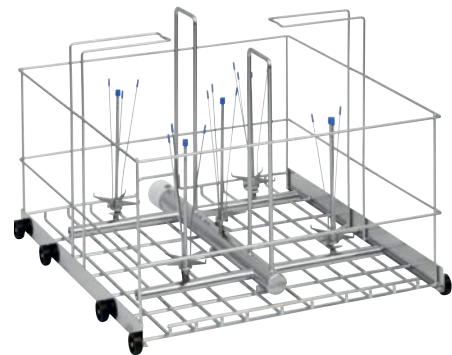

APLW 002 lower cart

- For bottles (5 and 10 l), large Erlenmeyer flasks
- Up to 4 items, Ø max mm 240
- Up to 5 items, Ø max mm 190
- 5 Injector nozzles
- H 300mm W 535mm D 580mm

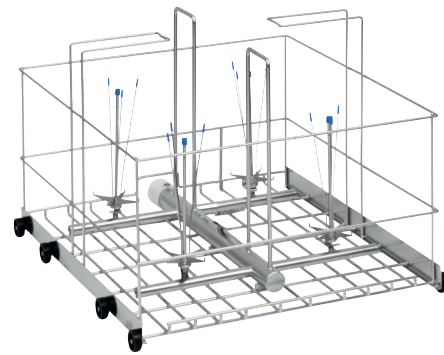

APLW 003 lower cart

- For bottles (up to 20 l), large Erlenmeyer flasks
- Up to 2 items, Ø max. mm 280
- 4 Injector nozzles
- H 300mm W 535mm D 580mm



APLW 004 lower cart

- For carboy bottles, max. 50 l
- Max diameter of carboy: 380mm
- Min. height of carboy: 620 mm
- Max. height of carboy: 560 mm
- Min inner diam. of carboy mouth: 30mm
- Max outer diam. of carboy mouth: 80mm
- H 545mm W 535mm D 580mm



APLW 005 lower cart

- For pipettes (max. 56)
- Max. pipette length: 760 mm
- Min. pipettes length for right side: 250mm
- Min. pipettes length for left side: 300mm
- H 310mm W 535mm D 575mm



APLW 006 lower cart

- For pipettes (max. 121)
- Max. pipette length: 620 mm
- Min pipette length: 135mm
- H 310mm W 535mm D 575mm

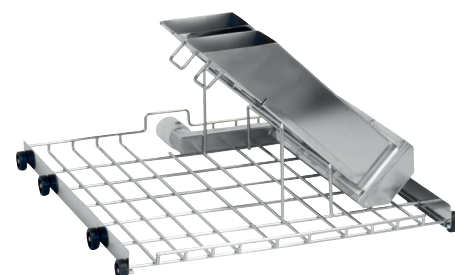

APLW 007 lower cart

- For pipettes (reprocessing in 2 cartridges)
- Max. pipette length 600 mm
- H 580mm W 535mm D 420mm



APLW 008 lower cart

- For pipettes (reprocessing in 3 cartridges)
- Max. pipette length: 300mm
- H 456mm W 179mm D 366mm



Upper and lower baskets with configurable nozzles

Basket layouts

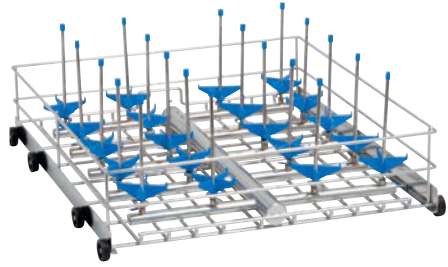

Basket layout 1

- Full-surface injector arrangement for medium-size laboratory glassware (upper or lower basket)
- Fig. shows example of APLW 026/1 lower basket

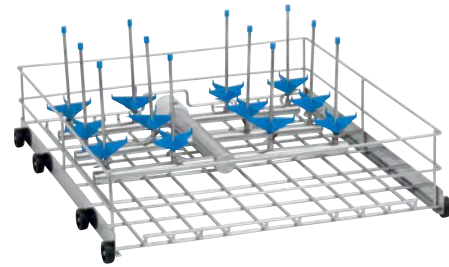

Basket layout 2

- Half-rack arrangement for laboratory glassware. Remaining area for example for inserts (upper or lower basket)
- Fig. shows example of APLW 030 lower basket

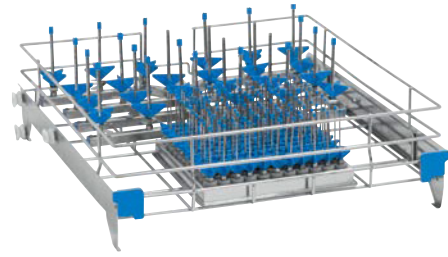

Basket layout 3

- Half-rack injector arrangement for medium to small laboratory glassware items (upper or lower basket)
- Fig. shows example of APLW 018/1 upper basket

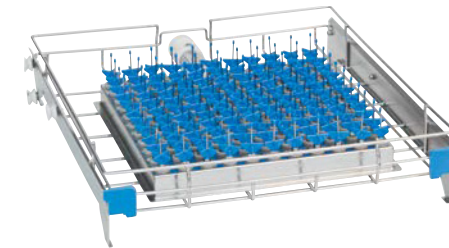

Basket layout 4

- Full-surface injector arrangement for small laboratory glassware items (upper or lower basket)
- Fig. shows example of APLW 019/1 upper basket

Upper and lower baskets, with pre-fitted nozzles

Basket versions

Upper basket	Glassware Ø max. mm	Max. height mm	Basket layout	Pre-fitted injectors
APLW 013/1	70	160	2	42x APLW 051
APLW 013/2	70	200 - 300	2	32x APLW 051 + 10x APLW 055
APLW 014/1	100	230	1	20x APLW 055
APLW 018/1	20 + 75	160	3	121x APLW 048 + 24x APLW 051
APLW 019/1	25	90	4	121x APLW 047

Lower basket	Glassware Ø max. mm	Max. height mm	Basket layout	Pre-fitted injectors
APLW 020/1	25	140	4	121x APLW 047
APLW 024/1	70	230	1	42x APLW 052
APLW 024/2	70	200 - 300	1	10x APLW 055 + 32x APLW 051
APLW 024/3	70	180 - 280	1	12x APLW 067 + 30x APLW 066
APLW 025/1	70	200 - 300	2	12x APLW 056 + 12x APLW 052
APLW 026/1	100	300	1	20x APLW 056
APLW 30/1	100	180 - 280	2	6x APLW 067 + 6x APLW 066
APLW 032/1	20 + 75	160 - 300	3	121x APLW 048 + 24x APLW 056

Upper and lower baskets, empty, freely configurable with nozzles

Basket versions

Upper basket	Glassware Ø max. mm	No. of injector positions	Basket layout	Note
APLW 010	32	156	1	only for 2.5 mm Ø nozzles
APLW 011	40	110	1	only for 2.5 mm Ø nozzles
APLW 012	35	84	1	only for 2.5 mm Ø nozzles
APLW 013	70	42	2	
APLW 014	100	20	1	
APLW 015	110	16	1	
APLW 016	75	27	1	
APLW 017	20	121	2	200x490 mm grid
APLW 018	75	24+121	3	See also APLW 035, APLW 034, APLW 036
APLW 019	25	121	4	only for 2.5 mm Ø nozzles

Lower basket	Glassware Ø max. mm	No. of injector positions	Basket layout	Note
APLW 020	25	121	4	only for 2.5 mm Ø nozzles
APLW 021	40	110	1	only for 2.5 mm Ø nozzles
APLW 022	52	70	1	only for 2.5 mm Ø nozzles
APLW 023	60	56	1	only for 2.5 mm Ø nozzles
APLW 024	70	42	1	
APLW 025	70	24	2	230 x 490 mm usable space
APLW 026	100	20	1	
APLW 027	110	16	1	
APLW 028	75	27	1	
APLW 029	130	12	1	
APLW 030	100	12	2	220x490 mm grid
APLW 031	160	9	1	
APLW 032	75	24+121	3	See also APLW 035, APLW 034, APLW 036

Injector nozzles for configuration of baskets



Nozzle type 1

- Standard support, Ø 4 mm for test tubes, low-capacity measuring cylinders, centrifuge tubes
- APLW 045 -046



Nozzle type 2

- Standard support, Ø 5 mm for narrow-necked glasses, measuring cylinders
- APLW 047 - 050



Nozzle type 3

- Standard support with spring clamp, Ø 5 mm for narrow-necked glasses, measuring cylinders
- APLW 051- 052



Nozzle type 3

- Standard support, Ø 10 mm for narrow-necked glasses, measuring cylinders
- APLW 053 -057

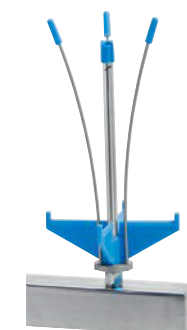

Nozzle type 4

- Flexible support, interior Ø 10 mm for Erlenmeyer flasks, wide- and narrow-necked glasses, measuring cylinders, Imhoff flasks
- APLW 058 - 060



Nozzle type 5

- Rigid support, interior, Ø 10 mm for wide-necked bottles, Erlenmeyer flasks
- APLW 061 -065



Nozzle type 6

- Rigid support, exterior Ø 10 mm for Erlenmeyer flasks, wide- and narrow-necked glasses, measuring cylinders, Imhoff flasks
- APLW 066 -068



Nozzle type 7

- Rigid support, Ø 17 mm for Erlenmeyer flasks, laboratory bottles, funnels, measuring cylinders
- APLW 069 -071

Suitable injection nozzle



APLW 046 to 049



APLW 053 to 057



APLW 058 to 060

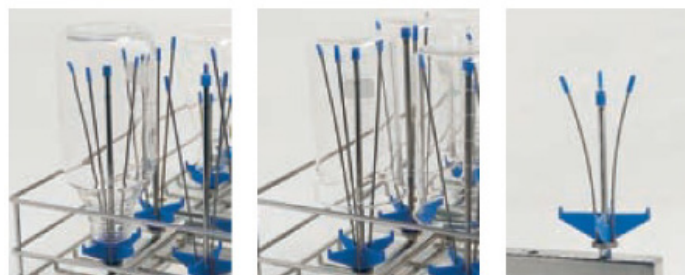

APLW 061 to 065



APLW 066 to 068



Depending on the form and size of loads, injector nozzles should be chosen to give a gap between the tip of the nozzle and the base of the glass of between 10 and 90 mm. Various nozzles can be supplied with a spring clamp for height adjustment. By adjusting the spring clamp, it is possible to reprocess laboratory glassware in a variety of sizes.

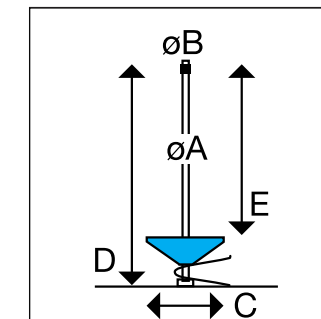
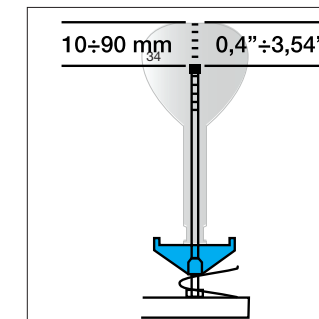

A diameter: outer diameter of the nozzle
 B diameter: diameter of the top cap
 C: max. diameter/width of base support
 D: total height when mounted on basket
 E: usable nozzle length
 D-E: height adjustment

	Ø A mm	Ø B mm	C mm	D mm	E mm	Type	Height adjustable clamp
Standard support, Ø 4 mm for test tubes, low-capacity measuring cylinders, centrifuge tubes							
APLW 045	2.5	4	15	80	75	1	No
APLW 046	2.5	4	15	80	80	1	No
Standard support, Ø 5 mm for narrow-necked glasses, measuring cylinders							
APLW 047	2.5	4	32	80	60	2	No
APLW 048	2.5	4	32	50	30	2	No
APLW 049	2.5	4	32	155	135	2	No
APLW 050	4	5	54	75	50	2	No
APLW 051	4	5	54	110	80	3	Yes
APLW 052	4	5	54	175	130	3	Yes
Standard support, Ø 10 mm for narrow-necked glasses, measuring cylinders							
APLW 053	6	10	75	115	85	3	No
APLW 054	6	10	75	135	95	3	Yes
APLW 055	6	10	75	175	130	3	Yes
APLW 056	6	10	75	225	185	3	Yes
APLW 057	6	10	75	275	235	3	Yes
Flexible support, interior Ø 10 mm for Erlenmeyer flasks, wide- and narrow-necked glasses, measuring cylinders, Imhoff flasks							
APLW 058	6	10	75	135	105	4	No
APLW 059	6	10	75	225	185	4	Yes
APLW 060	6	10	75	275	235	4	Yes
Rigid support, interior, Ø 10 mm for wide-necked bottles, Erlenmeyer flasks							
APLW 061	6	10	75	115	85	5	No
APLW 062	6	10	75	135	95	5	Yes
APLW 063	6	10	75	175	130	5	Yes
APLW 064	6	10	75	225	185	5	Yes
APLW 065	6	10	75	275	235	5	Yes
Rigid support, exterior Ø 10 mm for Erlenmeyer flasks, wide- and narrow-necked glasses, measuring cylinders, Imhoff flasks							
APLW 066	6	10	Flexible	175		6	No
APLW 067	6	10	Flexible	225		6	No
APLW 068	6	10	Flexible	275		6	No
Rigid support, Ø 17 mm for Erlenmeyer flasks, laboratory bottles, funnels, measuring cylinders							
APLW 069	8	17	87	255	235	7	No
APLW 070	8	17	87	320	300	7	No
APLW 071	8	17	105	320	300	7	No

Injector nozzle accessories



APLW 080 holder

- Ø 6 mm
- Height: 140 mm

APLW 081 holder

- Ø 6 mm
- Height: 186 mm

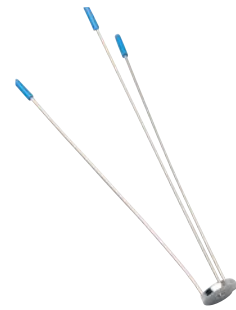

APLW 082 bottle support

- Securing of load
- Ø 6 mm
- Height: 200 mm

APLW 083 bottle support

- Securing of load
- Ø 6 mm
- Height: 130 mm



APLW 093 irrigation sleeve

- Pipette holder with silicone liner (max. Ø 11 mm)
- Height 123mm



APLW 090 holder

- Holder for pipettes
- Ø 20 mm
- Height: 21 mm



APLW 048 / 045 support

- for Injector nozzle
- diameter 2.5mm



APLW 091 cap

- closing unused holes
- Ø 25 mm
- Height: 13 mm



APLW 084 bottle neck holder

- Ø 28 mm
- for injector, Ø 6 mm
- Height 43mm

APLW 085 bottle neck holder

- Ø 33 mm
- for injector, Ø 6 mm
- Height 43mm

APLW 086 bottle neck holder

- Ø 45 mm
- for injector, Ø 6 mm
- Height 70mm



APLW 078 nozzle cap

- Cap
- Ø 10 mm for injector, Ø 6 mm
- Height 12mm

APLW 079 support

- Star support
- Ø 75 mm for injector, Ø 6 mm
- Height 28.5mm



APLW 088 holder

- Ø 105 mm H = 290 mm
- for injector, Ø 8 mm
- APLW 069 -070



APLW 092 blanking stopper

- Seal



APLW 073 support

- Star support
- Ø 32 mm for injector, Ø 2.5 mm
- Height 15mm

APLW 074 support

- Conical support
- Ø 15 mm for injector, Ø 2.5 mm
- Height 22mm

APLW 075 nozzle cap

- Cap
- Ø 4 mm for injector, Ø 2.5 mm



APLW 076 support

- Star support
- Ø 54 mm for injector, Ø 4 mm
- Height 22mm

APLW 077 nozzle cap

- Cap
- Ø 5 mm for injector nozzle, Ø 4 mm
- Height 7.5mm



APLW 087 support

- Stainless steel support
- Ø 87 mm
- for injector, Ø 8 mm
- Height 17mm



APLW 089 adapter

- Adapter
- Ø 6 mm adapter nipple
- for nozzle, Ø 8 mm

APLW 072 blanking screw

- For sealing nozzle connectors not in use



Process chemicals

ProCare Lab

Miele Professional has designed a comprehensive and systematic approach to the thorough and effective reprocessing of laboratory glassware and utensils. Alongside lab washers and tailored programs, this system also comprises process chemicals - a critical factor in cleaning. Geared meticulously to the requirements of individual program phases, specially formulated detergents and neutralising agents guarantee thorough, fast and gentle process cycles.



Quality from Miele Professional:

Process chemicals for the perfect reprocessing of laboratory glassware and equipment



ProCare Lab process chemicals are ideally suited to a multitude of applications, ensuring the trace-free removal of a wide range of soils in lab washers. At the same time, the process takes extreme care of loads. That is why Miele Professional is recommended by leading manufacturers of laboratory glassware.

The new ProCare Lab process chemicals have undergone extensive laboratory tests to ensure that they match the performance of high-performance lab washers from Miele Professional. Consequently, users profit highly from immaculate reprocessing for their analytical experiments, benefit from the value of their equipment being maintained and from fast glassware turnaround times.

A broad range of powder and liquid detergents are available to cover the various applications. The packaging of the various products is color-coded in order to reduce the risk of mix-ups.





- ProCare Lab 10 MA
- Alkaline detergent
- Liquid
- Container size 10 l



- ProCare Lab 10 AP
- Alkaline detergent
- Liquid
- Container sizes 5 l, 10 l



- ProCare Lab 10 AT
- Alkaline detergent
- Liquid
- Container size 5 l



- ProCare Lab 10 AO*
- Alkaline detergent
- Liquid
- Container size 5 l



- ProCare Lab 11 AP
- Alkaline detergent
- Powder
- Container size 10 kg



- ProCare Lab 30 C
- Acidic neutralizing agent based on citric acid
- Liquid
- Container sizes 5 l, 10 l



- ProCare Lab 30P
- Acidic neutralizing agent based on phosphoric acid
- Liquid
- Container sizes 5 l, 12 kg



- ProCare Lab Universal 61
- Coarse special salt
- Container size 6 kg



- Canister key
- Simplifies the opening of firmly tightened safety caps

*Note: When using detergents with active chlorine, increased wear of organic materials such as plastics and elastomers in the lab washer is to be expected. A temperature of 75°C should therefore not be exceeded in main wash cycles when using detergents containing higher concentrations of chlorine. In order to prevent such wear and tear, Miele recommends that machines be serviced annually or after 1000 operating hours. A failure to perform regular maintenance may invalidate guarantee and warranty claims. Please contact Miele Service or request an offer for a maintenance contract.

Note: Additional detergents available - please contact your Miele representative for more info.

ProCare Lab

Properties

Product	Container size	Properties	Ingredients	pH range
Main wash				
● ProCare Lab 10 MA	10 l	Liquid, alkaline Free from: Tensides and oxidative agents	Alkali hydroxide Phosphates Silicates	11.6-11.8 ²
● ProCare Lab 10 AP	5 l, 10 l	Liquid, alkaline Free from: Tensides, Phosphates and oxidative agents	Alkali hydroxide Polycarboxylates	12.5-12.7 ²
● ProCare Lab 10 AT	5 l	Liquid, alkaline contains tensides Free from: Phosphates, silicates and oxidative agents	Alkali hydroxide Polycarboxylates Tensides	12.2-12.5 ²
● ProCare Lab 10 AO*	5 l	Liquid, alkaline Oxidative Free from: Tensides	Alkali hydroxide Phosphates Chlorine bleach	11.8-12.1 ²
● ProCare Lab 11 AP	10 kg	Powder, alkaline Oxidative Free from: Phosphates,	Oxygen bleach Tensides	11.5-11.7 ¹
Neutralisation				
● ProCare Lab 30 C	5 l, 10 l	Liquid Acidic (based on citric acid) Free from: Tensides and phosphates	Citric acid	2.9 -2.5 ³
● ProCare Lab 30 P	5 l, 12 kg	Liquid Acidic (based on citric acid) Free from: Tensides and phosphates	Phosphoric acid	2.2-1.9 ⁴
Reactivating				
● ProCare Lab Universal 61	6 kg	Coarse special salt for reactivation of built-in water softener		

¹ pH value (determined using fully demineralised water at 20°C) 2 to 4 g/l

² pH value (determined using fully demineralised water at 20°C) 2 to 4 g/l

³ pH value (determined using fully demineralised water at 20°C) 1 to 4 g/l

⁴ pH value (determined using fully demineralised water at 20°C) 1 to 3 g/l

ProCare Lab

Properties

Product	Container size	Properties	Ingredients	pH range
Main wash				
● ProCare Lab 10 MA	5 l, 10 l	Liquid, mildly alkaline Free from: Tensides and oxidative agents	Alkali hydroxide Phosphates Silicates	11.6-11.8 ²
● ProCare Lab 10 AP	5 l, 10 l	Liquid, alkaline Free from: Tensides, Phosphates and oxidative agents	Alkali hydroxide Polycarboxylates	12.5-12.7 ²
● ProCare Lab 11 MA	10 kg	Powder, mildly alkaline Foam-retardant action Free from: Oxidative agents	Phosphates Silicates Tensides	11.7-11.9 ¹
● ProCare Lab 11 AP	10 kg	Powder, alkaline Oxidative Free from: Phosphates,	Oxygen bleach Tensides	11.5-11.7 ¹
Neutralisation				
● ProCare Lab 30 C	5 l, 10 l	Liquid Acidic (based on citric acid) Free from: Tensides and phosphates	Citric acid	2.9 -2.5 ³
● ProCare Lab 30 P	5 l, 12 kg	Liquid Acidic (based on citric acid) Free from: Tensides and phosphates	Phosphoric acid	2.2-1.9 ⁴
Reactivating				
● ProCare Lab Universal 61	6 kg	Coarse special salt for reactivation of built-in water softener		



- **ProCare Lab 10 MA**
- Mildly alkaline detergent
- Liquid
- Container size 5 l
- Art.No. 10265670



- **ProCare Lab 10 AP**
- Alkaline detergent
- Liquid
- Container sizes 5 l, 10 l



- **ProCare Lab 11 MA**
- Alkaline detergent
- Liquid
- Container size 10 l



- **ProCare Lab 11 AP**
- Alkaline detergent
- Powder
- Container size 10 kg



- **ProCare Lab 30 C**
- Acidic neutralizing agent based on citric acid
- Liquid
- Container sizes 5 l, 10 l



- **ProCare Lab 30 P**
- Acidic neutralizing agent based on phosphoric acid
- Liquid
- Container sizes 5 l, 12 kg

- **neodisher®**
- LaboClean A8 (Powder, 10 kg)
- LaboClean F (Powder, 3 kg)
- LaboClean FT (Liquid, 12 kg)
- LaboClean GK (Powder, 10 kg)
- LaboClean LA (Powder, 3 kg)



- **ProCare Lab Universal 61**
- Coarse special salt
- Container size 6 kg



- **Canister key**
- Simplifies the opening of firmly tightened safety caps

Note: When using detergents with active chlorine, increased wear of organic materials such as plastics and elastomers in the lab washer is to be expected. A temperature of 75°C should therefore not be exceeded in main wash cycles when using detergents containing higher concentrations of chlorine. In order to prevent such wear and tear, Miele recommends that machines be serviced annually or after 1000 operating hours. A failure to perform regular maintenance may invalidate guarantee and warranty claims. Please contact Miele Service or request an offer for a maintenance contract.

¹ pH value (determined using fully demineralised water at 20°C) 2 to 4 g/l
² pH value (determined using fully demineralised water at 20°C) 2 to 4 g/l
³ pH value (determined using fully demineralised water at 20°C) 1 to 4 g/l
⁴ pH value (determined using fully demineralised water at 20°C) 1 to 3 g/l



Miele Professional

Top-notch quality and service

Decades of experience, an unerring pursuit of quality and the power of innovation means that Miele sets the benchmark. High-performance lab washers from Miele Professional are recommended by leading manufacturers of laboratory glassware. In combination with accessories specific to models and applications, machines from Miele Professional facilitate the fast and simple reprocessing of all types of glassware.

Performance

- Thorough yet gentle reprocessing with dependable results
- Process control perfectly matches machines and laboratory glassware
- All-in system from one single supplier consisting of perfectly matching components (machines, chemicals, software, service)

Quality and economic operation

- Highest-quality materials and workmanship
- Superior product longevity and reduced need for maintenance
- Short cycle times and sparing use of resources

Safety and convenience

- Ergonomic controls simplify everyday laboratory work
- Convenient navigation avoids incorrect program selection
- Large-scale, easy-to-read text display
- Possibility to document wash cycle parameters

Service

- Excellent Miele in-house service operation offering blanket coverage.
- Comprehensive advisory services covering planning, requirement assessment and financing.
- Customised service contracts guaranteeing functional safety and preserving values.



Service excellence

Maintenance and service contracts



Available Miele service options

- Preventative maintenance
- Full-service maintenance contract
- Machine qualification - IQ/ OQ

Comprehensive service from the very start

Even before a machine is installed, Miele's sales force is available to provide clients with in-depth advice. Experienced experts assist in selecting the most suitable machines and configurations to suit individual needs. Between our application specialist and experienced call center staff, we are ready to support the product at any stage of its life span.

Service to meet professional expectations

Highly qualified service engineers oversee the install and commissioning of machines and are available to perform preventative maintenance over the course of the machine's lifetime. This prevents faults occurring in the first place and offers an opportunity to optimize operating parameters on an ongoing basis. Delivery and commissioning of machines and are available to perform various routine checks during the course of the machine's lifetime.

Additional advantages:

- Regular checks and maintenance safeguards investments.
- First-class service with our network of technicians
- Reliable spares service, key functional parts available for 15 years after series production ceases.

Preventative maintenance and service contracts

Miele Professional offers laboratories options for having regular preventative maintenance as well as service contracts. Utilizing both of these option provides an analysis of functionality and safety with respect to all key components, including replacement as and when necessary. Scheduled maintenance prevents breakdowns from happening in the first place, increases the life expectancy of machines and contributes towards safeguarding investments. This offer from Miele Service includes a whole range of performance and process checks.

Excellent Miele in-house service operation offering extended coverage. Comprehensive advisory services covering planning, requirement assessment and technical support. Service contracts guaranteeing functional safety and preserving values.



Miele Inc.

9 Independence Way
Princeton, NJ 08540

Toll Free: 800-991-9380
Fax: 609-419-4241

proinfo@mieleusa.com
www.mieleusa.com/professional



Miele Limited

161 Four Valley Drive
Vaughan, ON, L4K 4V8

Toll Free: 888-325-3957

professional@miele.ca
www.mieleprofessional.ca



since 1899

Forever Better

Since 1899, Miele – a family run company – has subscribed to a clear corporate philosophy condensed into the two words “Forever better.” This far-reaching claim is the bedrock of Miele’s proverbial quality and sustainability and the power of innovation of a brand “Made in Germany.” A brand promise which gives commercial users the certainty of having chosen the right product.

Award-winning

Uncompromising product reliability and service dependability is the reason why customers have repeatedly voted Miele the best and most trustworthy brand. Coveted awards such as the MX Award, the iF and reddot Design Awards and the German Sustainability Prize confirm the distinguished position Miele enjoys with respect to design, quality management and the sparing use of resources.

Proficient

Miele Professional has been developing and manufacturing a broad range of high quality laundry machines, dishwashers, washer-disinfectors and sterilizers for decades. Carefully selected accessories, comprehensive advisory services and a fast-acting Miele service department ensures that machines perform to satisfaction and offer the ultimate in performance and efficiency.